

SIM 00476

# Biocontainment design considerations for biopharmaceutical facilities

Steven R. Miller and Don Bergmann

*SmithKline Beecham Pharmaceuticals, King of Prussia, PA, USA*

*Key words:* Biosafety; Biocontainment; Biopharmaceutical design; Biological inactivation

---

## SUMMARY

This article highlights biocontainment design considerations for biopharmaceutical manufacturing facilities. The major focus of this report is on industry's use and interpretation of the regulations with specific design recommendations for a Biosafety Level 2 – Large -Scale physical containment level as described by the National Institutes of Health Guidelines.

---

## INTRODUCTION

The first biopharmaceutical facilities for large-scale cultivation of recombinant microorganisms were designed and commissioned over 10 years ago. Since that time, several research, development, and manufacturing facilities have been built, and designers have established certain standards that have become accepted by industry.

These standards have their origin in the guidelines developed by the National Institutes of Health and amended many times since their first issue in the mid 1970s. Recent revisions of these guidelines have defined a new biological containment category designated as Good Large-Scale Practices (GLSP). This containment category is intended to include organisms that pose no known risk to the environment. Establishing this category is the result of many years of safe industrial use of a number of organisms that do not pose a risk to the environment; and indicates an increasing comfort level by regulatory authorities with recombinant biopharmaceutical processing and the industry's design practices.

This article describes design practices as they exist today. The effect of the establishment of the GLSP category on these practices is not yet evident. It is expected, that over time, certain containment designs will be modified and somewhat relaxed for this class of organisms. At

the same time, certain designs, while not required for containment, may continue to be used to effect contamination control (i.e., preventing contamination by organisms external to the equipment).

## CONTAINMENT LEVELS

The first step in the process of determining appropriate biocontainment design is to determine the required physical containment level. Physical containment levels were established by the National Institutes of Health (NIH) in the 'Guidelines for Research Involving Recombinant DNA Molecules' [7]. Four levels of containment were introduced for large-scale research or production. Large-scale is defined as cultures of more than 10 liters. Biosafety levels set containment conditions dependent on the assessment of the degree of hazard to health or the environment posed by the organism in use. The four containment levels are referred to as Good Large-Scale Practice (GLSP), Biosafety Level 1 – Large Scale (BL1-LS), Biosafety Level 2 – Large Scale (BL2-LS), and Biosafety Level 3 – Large Scale (BL3-LS). The lowest containment level is GLSP and increases through to BL3-LS.

Biological processes are assigned to containment levels based on an evaluation of the pathogenicity or toxicity of the host organism or the gene product. Each organization performing recombinant DNA research or production must have an Institutional Biosafety Committee (IBC) that reviews and approves work with recombinant organisms. The IBC, working under the guidance of the Recombinant Advisory Committee (RAC) of the NIH,

---

Correspondence to: Steven R. Miller, SmithKline Beecham Pharmaceuticals, P.O. Box 1539, King of Prussia, PA 19406, USA.

determines the appropriate physical containment level for each recombinant strain.

In general, industrial processes use recombinant organisms with very low levels of risk and/or that have a history of safe industrial use (GLSP). For example, *Escherichia coli* strain K-12 derivatives are used to produce human insulin and human growth hormone, yeast strains are used to produce human insulin and hepatitis vaccines, and Chinese hamster ovary (CHO) cells are used to make tissue plasminogen activator (TPA) and erythropoietin (EPO). Typically, a facility constructed to produce quantities of these products could be designed to GLSP or at most to BL1-LS standards since these host-vectors meet the criteria of GLSP as described in this issue [14]. However, the tendency in the biopharmaceutical industry has been to take a conservative approach to risk. This results in many firms electing to design to a containment level above that required.

Such a design approach does carry its own inherent risks. While capital costs for facilities are higher, there is a more important consideration. That is, does the installation of extra safeguards send conflicting signals to a public which may not be knowledgeable about the safety of the organisms being used? Over-designing may raise questions about the confidence a firm has in the real risks of a particular operation and may support perceptions that such production facilities are unsafe. However, designing to a containment level above that required does allow flexibility to accommodate changes in the host expression system utilized in the facility or revisions to the regulations. Typically, the costs involved in designing to BL2-LS level is a minor increment over BL1-LS. As such, one may want to consider designing a biopharmaceutical facility to meet BL2-LS requirements, although the agents produced could be classified as either GLSP or BL1-LS. Rather than describing the specific design requirements for each of the physical containment levels, the following are general standards used in industry which comply with BL2-LS guidelines.

## FACILITY DESIGN CRITERIA

Facility issues center around the building requirements for biopharmaceutical operations and can be further divided into the following categories.

### *Architectural finishes*

In general, all containment area surfaces must be easily cleanable. Bench tops and equipment surfaces should be impervious to water and resistant to the chemicals used. Typically, stainless steel or epoxy tops with baked epoxy painted steel casework are used in industrial biological process areas. Where decontamination or sanitization by

hypochlorite is the practice, epoxy bench tops replace stainless steel which can be attacked by exposure to hypochlorite.

Placement of equipment and furniture must allow for proper cleaning. This is best accomplished by locating equipment off the floor or on housekeeping pads. Preferably, equipment is hung off walls or from overhead supports and floor supports and penetrations are eliminated. When this is not practical, seal and cove the flooring around equipment to prevent seepage of spills.

The floors must be sealed and of a texture that allows for complete cleaning. The finished floor texture must be optimized for cleanability, while retaining a degree of resistance to prevent slipping when wet. Floor and wall samples should be provided by the installer. Even with samples, it is suggested that a test area be completed for evaluation. Troweled epoxy, terrazo, and Mipolam are three different types of floor materials suitable for this service. Floor-to-wall joints should be coved.

Walls and ceiling should be nonporous and finished with a water resistant material. Epoxy-painted gypsum wallboard is typically used, but other wall finish options, such as Descoglas and Mipolam construction, are available. The latter wall finishes are more costly and are not required unless a cleanroom environment is desired. In situations where equipment movement may damage walls, consider employing some type of impact protection such as PVC or Mipolam wainscot or stainless steel sheet metal attached to the working height of the walls. Plastic-faced suspended ceiling tiles can be used in place of wallboard for ceiling construction. This allows easy access to services and equipment located above the ceiling. If wallboard is used, locate required access hatches or design an accessible mechanical space.

### *Washing facilities*

Facilities for personal hygiene must be available appropriate to the risks of exposure to the organism. Workers should wash their hands with an appropriate disinfectant soap before leaving the containment area. For washing hands, a simple stainless sink is suggested. A hand air dryer eliminates the need for paper or cloth towels.

### *Garments*

It is general practice in industry to issue uniforms to operation personnel. Lab coats over street clothing or uniforms are sufficient for BL2-LS biocontainment areas. Lab coats should be restricted to their area of use and should not be worn into cafeterias or general office areas.

Personnel should wear safety glasses, goggles, or splash shields as appropriate. Other garments may include shoe covers and/or hair covers. However, these are used for contamination control rather than as a containment re-

quirement. A change area or room at the biocontainment area entrance helps to confine these garments to the area.

### Security

In general, access into biopharmaceutical production areas is restricted to employees required for manufacturing. This is usually accomplished by posting signs, and using keyed locks, combination locks, or card readers at strategic entrances.

If viewing of operations is desired, a corridor with windows should be designed into the facility to allow tours without visitors needing to enter production areas.

It is desirable to minimize maintenance activity within the operating environment. Utility services and major mechanical systems may be located in adjacent but isolated areas away from the process operations. This will both minimize personnel exposure and keeps environmental contamination low.

### Signage

The universal biohazard warning sign must be posted outside of containment areas. Besides the biohazard warning symbol, the sign should include information on the biohazard containment level, list the agents in use, responsible personnel, gowning requirements, and an emergency contact available around the clock (Fig. 1). Security can be designated as the emergency contact. In this role, security typically functions as a communication center, notifying and directing appropriately trained personnel to the emergency.

### Ventilation

Primary containment is achieved by using closed systems or biological safety cabinets as required for BL2-LS operations. Ventilation or environmental controls can only function as a secondary containment.

Air flow requirements are not specified in the guidelines for BL2-LS biohazard level. Good manufacturing practices (GMPs) recommend that air flows cascade from process areas outward to non-process areas. However, depending upon the risk, one may consider designing the biocontainment area to operate at a negative pressure relative to surrounding areas. This reduces the spread of organisms in case of a failure of the primary containment. All penetrations into the controlled area should be sealed. An airlock may separate the controlled area and the rest of the facility. The airlock design may include a changing room for personnel access and a separate airlock for equipment movement.

The guidelines do not require HEPA filters in the facility supply or exhaust for BL2-LS operations. HEPA filters may be used, however, in supply air for environmental control especially for downstream processing. One



Containment Level: \_\_\_\_\_

Infectious Agents: \_\_\_\_\_  
 \_\_\_\_\_  
 \_\_\_\_\_

Responsible Personnel: \_\_\_\_\_ X- \_\_\_\_\_  
 (Include extension #) \_\_\_\_\_ X- \_\_\_\_\_  
 \_\_\_\_\_ X- \_\_\_\_\_  
 \_\_\_\_\_ X- \_\_\_\_\_

Special Requirements Before Entering: Lab Coat  
 Safety Glasses  
 Safety Shoes  
 Other \_\_\_\_\_

In the event of an emergency and if the personnel listed above cannot be reached, call Security (X-7300).

Fig. 1. Biohazard warning signage.

may consider HEPA filtering exhaust air as a secondary containment measure in facilities where aerosols may be generated. The number of air changes provided is dependent on the quality of air required and the heat load of the area. Twenty to thirty air changes per hour is not unusual.

## EQUIPMENT DESIGN CRITERIA

### Closed systems

Cultures of viable organisms are required by the guidelines to be contained within a closed system or primary containment device such as a biological safety cabinet (BSC).

Fermentation systems, which are designed to be closed systems to minimize or prevent contamination by external organisms, effectively serve to contain recombinant organisms within the fermentor and prevent their escape. Fermentor designs typically include sterile vent filters, sterile filters for sparging and overlay gases, and steam-lock addition ports. Fermentors should be designed for complete

drainability. The use of threaded components inside the vessels are to be avoided. Baffles should be welded, not bolted in-place. All deadlegs should be minimized.

#### *Biological safety cabinets*

Class II biological safety cabinets which provide a HEPA filtered air curtain are typically used for small open operations. This design provides operator protection as well as protection of the process inside the cabinet by the HEPA filtered air flow (Fig. 2). The HEPA filtered exhaust air from a BSC can be recirculated into the processing room, or in cases where noxious or hazardous vapors are generated, the exhaust can be ducted to further treatment or to the outdoors.

#### *Exhaust gases*

Exhaust gases from closed systems or primary containment devices must be treated to prevent the release of viable organisms. The guidelines suggest filtration or incineration as possible treatment processes. Filtration tends to be the method of choice in industry.

As previously mentioned, HEPA filters are used for biological safety cabinet treatment of exhaust gases. Recommendations on monitoring and testing these filters follow in a subsequent section.

Sterile 0.2-micron hydrophobic vent filters are typically used for industrial fermentation gas filtration. The filtration design should allow for in-place integrity testing of the system.

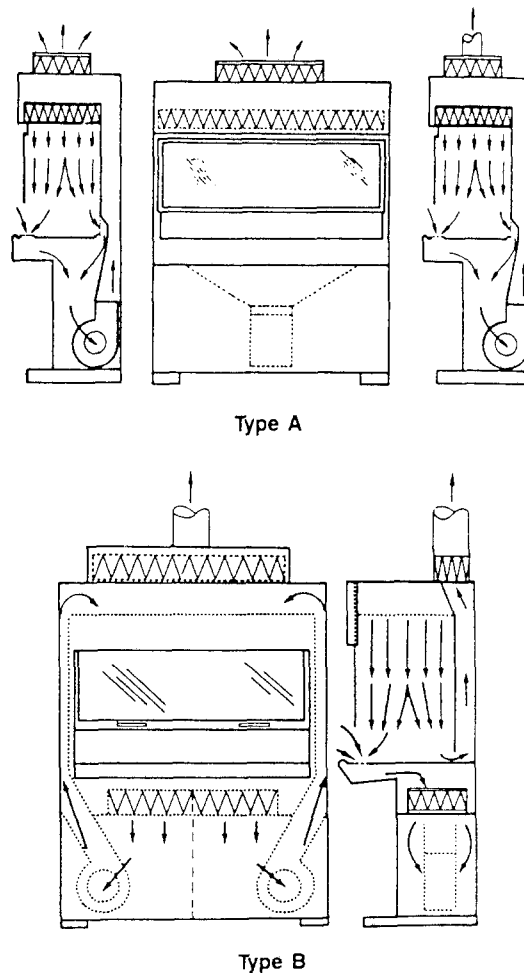

Fig. 2. Biological safety cabinets type II.

The major operational difficulty with vent filters is their tendency to foul and plug when they are wetted by moisture carried over with the exhaust gases or due to excessive foaming. In order to combat this problem, a condenser can be positioned between the fermenter and the filtration housing to reduce the vapor content and allow physical space for disengaging of aerosols. A cyclone can be inserted to further reduce moisture carryover prior to the filtration device (Fig. 3). In either case, these devices and piping must be sterilizable up to and through the vent filter to prevent contamination of the fermentation process.

Steam jacketed filter housings can also be used to minimize condensate. Care must be taken to prevent excessive heat to the filter housing which may damage the filter integrity. Another option is to position a coalescing filter prior to the sterile filter to reduce moisture carryover, but recognize that this coalescing filter would be within the sterile operation envelope. The coalescing filter must be sterilized as part of the venting system. Also, the coalescing filter can plug if the moisture load is too great or if excessive foaming occurs.

For low gas volume sparging processes, such as typical cell culture operations, the filter housing may be located directly on the fermentation vessel nozzle such that water vapors condense on the housing and return to the fermentor (Fig. 4). This simplifies the sterilization operation.

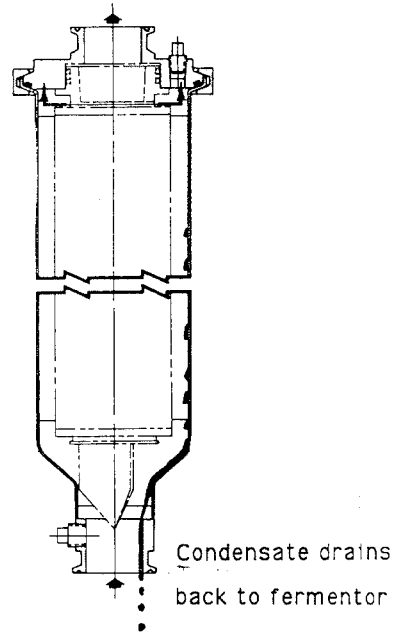

Fig. 4. Sterile vent filter – directly on fermentop.

#### Transfers

Transfers include the addition of material to or the removal of material from a closed system. Note that sampling is included under this definition. The guidelines require that exposure is prevented during transfers of

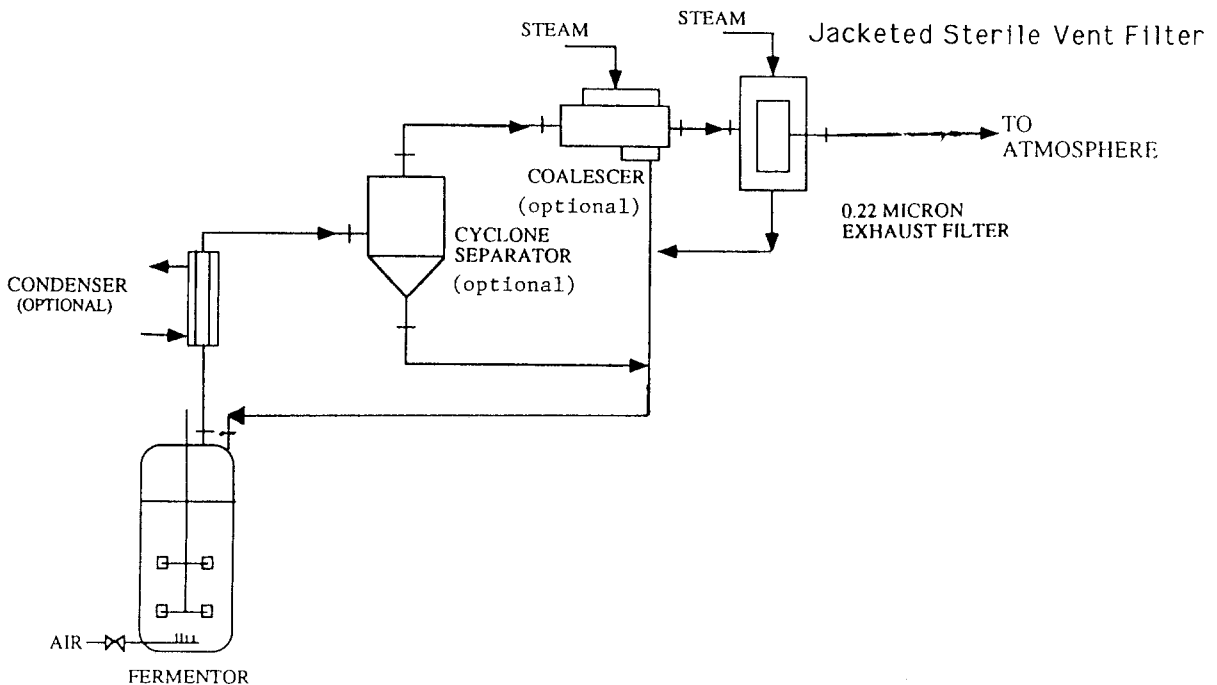

Fig. 3. Containment system for fermentor exhaust air (based on A. Moreira, *Controlling Biotechnology Risks*, SIMS Workshop).

BL2-LS cultures. This is usually accomplished by using steam lock addition ports (Fig. 5). This is another example where contamination control and containment principles overlap. Steamable addition ports or sample ports are sterilized prior to use to prevent contamination of the fermentation process. Following the collection of a culture sample, the port can be resterilized or decontaminated prior to breaking the connection. The sterilization process effectively inactivates any organism in the area of the connection. Designs must minimize the frequency of making or breaking connections or drawing samples in a manner that increases the potential for gross exposure via a splash or spray.

Aerosols of biological solutions are a particular concern. Centrifuges used in harvesting fermentation broth can generate aerosols. Large-scale centrifuges are now designed with the appropriate rotating seals to prevent the release of aerosols into the work environment. As an option, small uncontained centrifuges can be located within a BSC to contain this operation. Tangential flow filtration systems may be substituted for centrifugation and are less likely to cause an aerosol problem.

#### *Rotating seals*

In order to prevent exposure to viable organisms, the guidelines specifically require that rotating seals be designed to prevent leakage. This is generally accomplished by using double mechanical seals and flushing the chamber between the two seals with a barrier fluid (Fig. 6).

Condensed clean or pure steam is typically used as the seal flushing media (Fig. 7). The flush is then directed to the biological waste treatment system for inactivation as this stream may become contaminated in case of a seal failure and a resulting leak out of the process vessel into the seal chamber. A low pressure switch or low flow switch can be included to alarm if this barrier flush supply is lost. An automated supply shutoff which opens with power to the rotating driver helps to ensure the seal flush supply is present when, but only when, it is needed.

A drain tap below the seal can be used to indicate seal failures. The drain can be fitted with a collection tube. Any material in this tube indicates a possible seal failure.

#### *Monitoring integrity of containment*

Closed systems and primary containment devices should include sensing capability to monitor the integrity of containment. The seal leak detector design described above is one example of monitoring the integrity of your containment.

Biological safety cabinets (BSCs) generally include a flow switch which alarms when exhaust flows become too low. BSCs should have an indication of pressure drop across the HEPA filter which is further indication of proper operation. HEPA filters in BSC operations can last several years depending on their design and the dirt load of the operation. Certification of the HEPA filter performance by a DOP test is required when the device is installed, relocated, whenever the filter is changed, or on an annual basis.

Fermentation systems are often subjected to a pressure hold test prior to sterilization to demonstrate the integrity of the system. Most fermentors are pressure vessels, so pressure relief devices are required. The optimal design includes a rupture disk directly on the fermentor nozzle with minimal dead space between the rupture disk and the fermentation space (Fig. 8). A pressure safety valve is installed above the rupture disk. This allows for relief during over-pressurization with a return to containment following relief venting. A positive pressure on a pressure gauge between the rupture disk and the relief valve would indicate that the rupture disk has blown. As pressure safety valves are difficult to clean and sterilize, this design provides the pressure relief necessary without this complication.

#### *System identification*

It is a GMP requirement that all process equipment be identified and that use and maintenance records be kept, and this is reinforced by the guidelines for containment reasons. It is also important to record physical changes to closed systems and any testing following the changes which document continued proper operation of these systems.

Equipment tags must be easily visible, permanent, and capable of standing up to process conditions. Plastic tags should be avoided where hot surfaces may damage them.

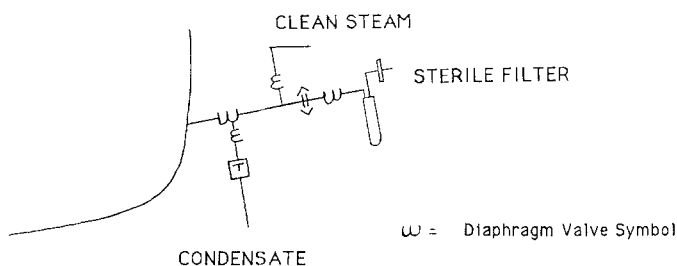

Fig. 5. Steamlock sample port.

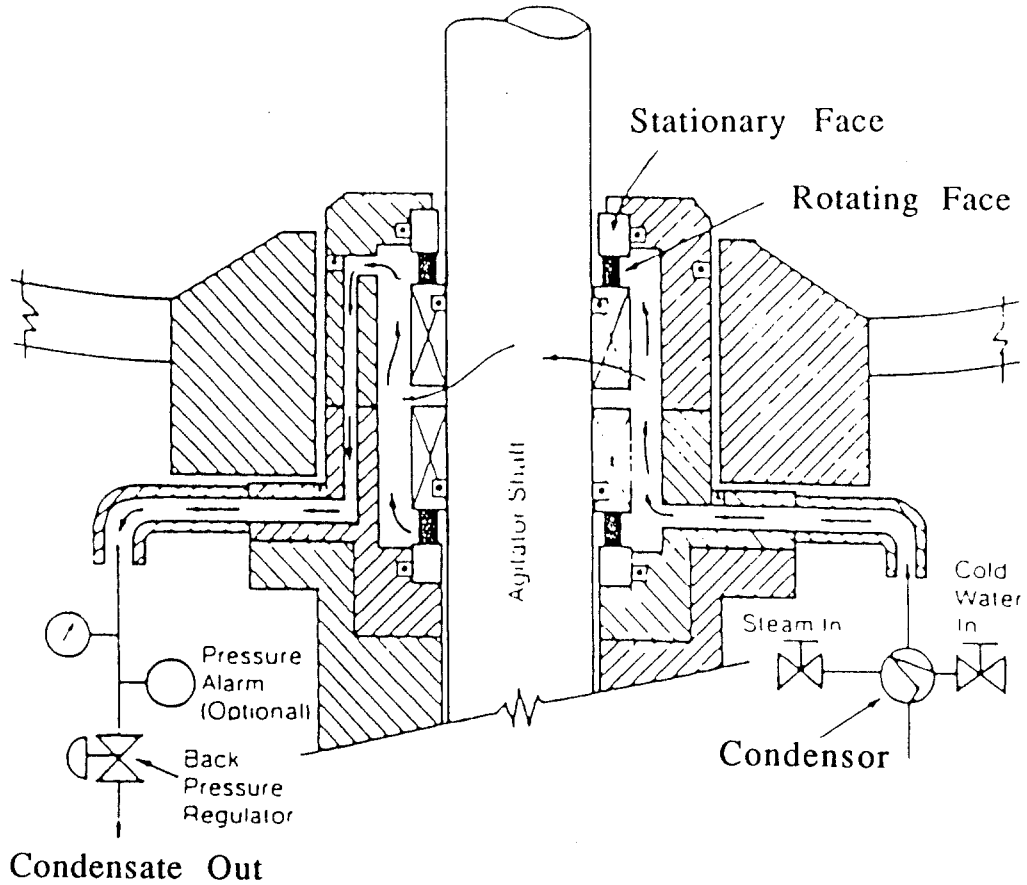

Fig. 6. Contained double mechanical seal (from J. Van Houten, *New Frontiers in Biosafety: The Industrial Perspective*).

Equipment log books or a computer database can be used to document the use, testing, and maintenance of and changes to systems.

**VALIDATION**

The GMPs require validation of systems involved in the production of product for use in humans. Facility, equipment, and process validation is a complex topic

which is beyond the scope of this discussion. However, one should plan the validation program during the design stages of the project in order to capture a complete set of documents and all the test data generated during inspections and startup. An effective change control program should be established to ensure that changes are recorded and revalidation testing is completed when necessary. The validation of biological inactivation systems is discussed in more detail in the next section.

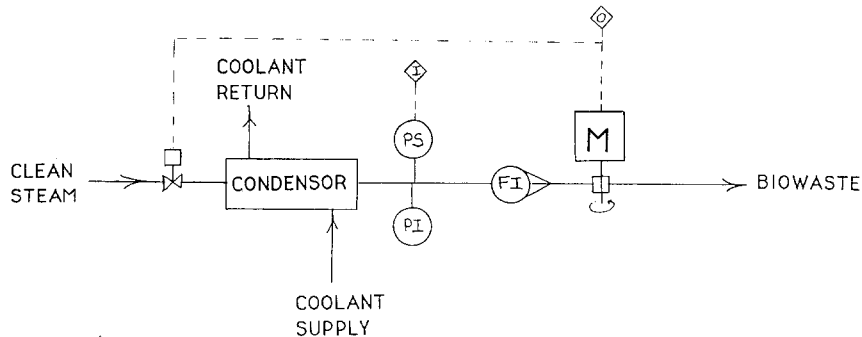

Fig. 7. Seal flush service.

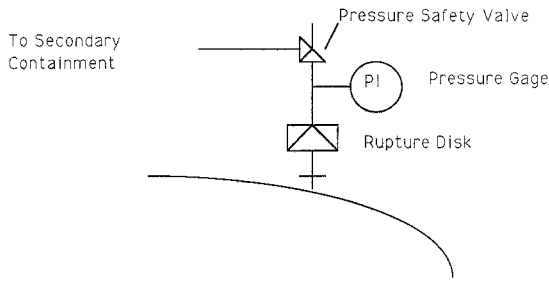

Fig. 8. Fermentor pressure relief design.

## WASTE TREATMENT

Discharges containing viable recombinant organisms from BL2-LS processes must be inactivated by a validated inactivation procedure prior to release from the closed system. This section covers the selection of inactivation methods, batch vs. continuous systems, and finally some critical design features necessary for proper operation of a biological waste treatment system.

The first question to be answered when designing a biowaste system, is how to inactivate the viable recombinant organism. The two most frequent techniques used to effect biological inactivation are thermal or chemical inactivation.

### *Thermal systems*

Of these two, thermal inactivation is the most common method selected for large scale use. Using this technique, biological waste is heated to a sufficient temperature and held at that temperature to ensure the inactivation of the recombinant organism. There is a large data and experience base in this area due to the studies completed in the development of sterilization technologies. In fact, it is not unusual to design the thermal inactivation cycle as you might a sterilization operation.

### *Chemical systems*

Chemical inactivation with agents such as hypochlorite (bleach) are very effective. However, this method is generally restricted to use on small volumes of biologically active wastes. The disadvantages of chemical systems are the additional hazards of the chemicals used. They can be corrosive and the addition of these chemicals may generate a waste with a chemical disposal problem.

### *Batch systems*

Biowaste inactivation treatment design as a batch system can match up well with waste flow as most fermentations are batch processes. One may elect to inactivate in the fermentor if this can be accomplished without product

degradation or a negative impact on downstream processing. Alternatively, one may decide to discharge biological waste to a biological inactivation system.

Batch design tends to allow for more flexibility than the typical continuous designs and are generally the design of choice for pilot plants or multi-product facilities. It also allows for confirmation of the effectiveness of the inactivation process on discrete batches. However, batch design tends to be more capital intensive and consumes more facility space.

The flow schematic in Fig. 9 shows a typical, dedicated, batch type, biological thermal inactivation system. In this system, biological waste drains by gravity from the processing operations located on floors above the biowaste collection vessels. One vessel is in service receiving waste. Once the level reaches a predetermined value, the inlet valving switches, and waste is directed to the other collection vessel. Valve sequencing is controlled by a programmable logic controller (PLC). The filled vessel is isolated, the mixer starts, and steam is supplied to the jacket to begin heating. Steam is also directed into the inlet line to purge and heat this line, and to aid in purging air from the head space over the collected waste in the vessel. Each vessel has a coalescing and sterile vent filter. The contents of the vessel are heated to and maintained at 121 °C for 30 min using a single loop controller. After the inactivation cycle, the waste is cooled below 60 °C using tower water to the vessel jacket. This is required prior to discharge to the process waste system. A circular chart recorder documents the inactivation process. Following cooldown, the inactivated waste is discharged to process aqueous waste. Once drained, this vessel waits in standby until it is again required.

### *Continuous systems*

Continuous inactivation is more typical in production plants where the character of the waste stream is more consistent and predictable. Biowaste can be heated, using a heat exchanger with sufficient residence time and discharged in a fashion similar to in-line media sterilization (Fig. 10). Continuous processes tend to be less flexible than batch designs, but demand less capital and can consume less facility space.

### *Validation*

The guidelines require that BL2 organisms are inactivated prior to discharge. A complete validation package will include an installation qualification, operation qualification, and a performance qualification.

The installation qualification documents that the equipment provided meets design specifications and is installed per vendor and design requirements. Areas included are: shop/field inspections of major components, inspection of



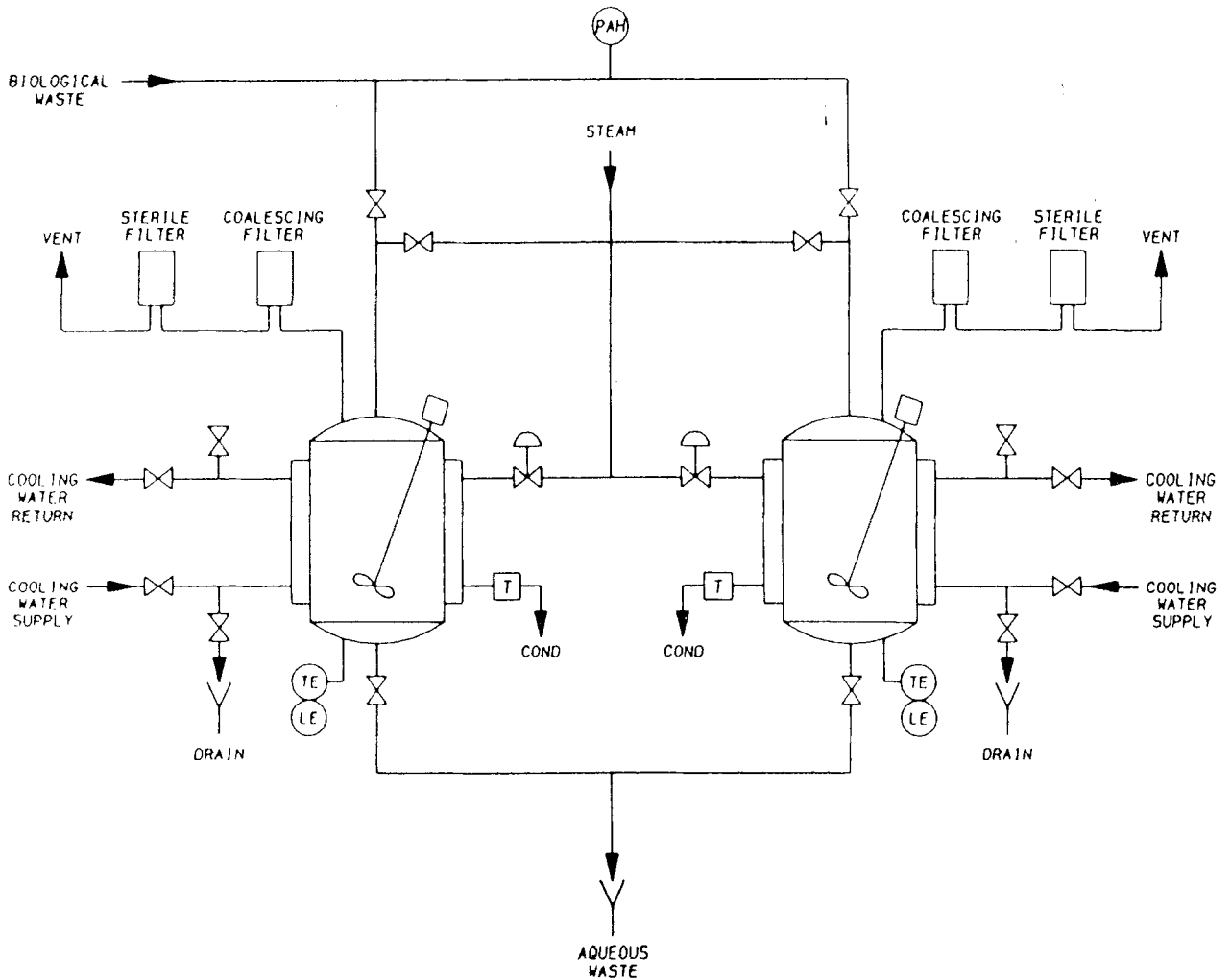

Fig. 9. Batch biological inactivation system.

materials of construction, checks that the system is installed per construction documents, proper slope on drainage piping, adequate labeling is in place, proper rotation on mixers and pumps, instruments are calibrated, and manuals and other operation support documents are available.

The operation qualification documents that the system operates as expected. This may include: alarm and interlock verification, control loop tuning, and sequential automated control logic is tested. This test usually involves a mock run using water to verify proper operation prior to actual use with viable organisms.

Performance qualification testing is designed to be an actual challenge to the system. The performance qualification of biological inactivation processes can be approached in a number of ways. If a thermal inactivation method is to be used, the system can be monitored using

thermocouples located in critical locations to validate that the system achieves the required temperatures. The best approach is to inactivate a volume of non-recombinant host organisms. The test organisms of choice should be non-recombinant host strains utilized in production. Alternately, in pilot plants where a wide range of host cells may be utilized, one may elect to test one or two of the host strains known to have the highest D-values and therefore to be the most heat resistant. By sampling before and after inactivation, the log reduction in activity can be determined. A minimum of a six log reduction should be demonstrated. Most systems are designed and operated to achieve a nine to twelve log reduction.

#### *Critical design features*

Biological inactivation systems may not get the respect that the design of fermentation systems do, but in many

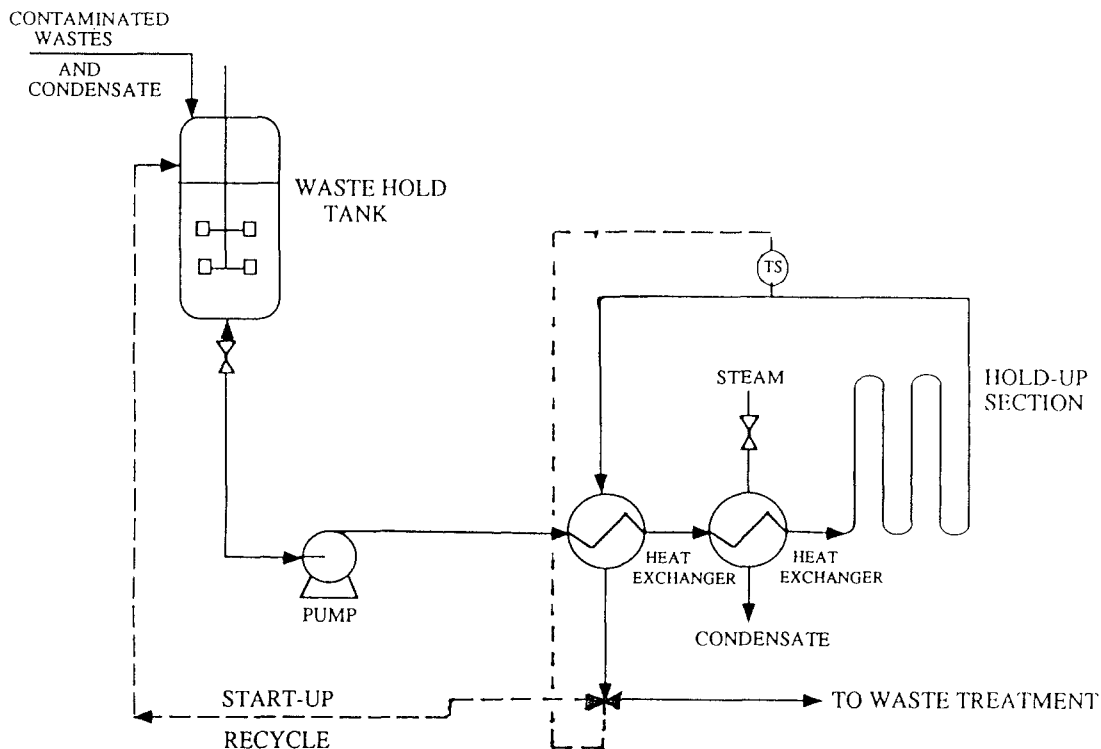

Fig. 10. Continuous biowaste kill system (based on A. Moreira, Controlling Biotechnology Risks, SIMS Workshop).

respects their design requirements are similar. Areas of particular concern include;

1. Adequate capacity: Do not overlook any of the waste streams. Use a generous safety factor so that plant capacity is not limited by the waste disposal system's capacity.

2. Appropriate materials of construction: Generally, 316L stainless steel is used for these welded systems. Other exotic materials may be required especially when chemical inactivation is selected.

3. Instrumentation needs to be sufficient to control and document the inactivation.

4. Lack of dead spots: Design the system as you would processing equipment. Watch valve locations and eliminate deadlegs. Filters must be adequately steamed. The head space over the waste must be purged of air pockets to ensure complete system inactivation temperatures are reached.

5. Odor control: If the plant is near a residential area, an exhaust scrubber or absorber may be required.

6. Chemical hazards: The waste, pre or post inactivation, may contain a chemical hazard that requires further attention. If so, neutralization or other treatment may be required.

#### Autoclave

An autoclave for the decontamination of solid waste materials or small portable equipment is also required. This should not be the same autoclave that is used for sterilization of raw materials or equipment. Decontamination autoclaves should be dedicated to decontamination only. This is not a containment requirement but a requirement of good manufacturing practices (GMPs). Watch the traffic pattern of material and waste flows. Crossing waste streams with incoming processing materials should be avoided. Double door autoclaves assist in preventing material cross contamination. The autoclave should be conveniently located to minimize the distance from processing to the point of decontamination.

#### SPILL RESPONSE

Biological processing requires that a response plan be developed for dealing with spills. This includes procedures for evacuation, spill containment, decontamination and cleanup.

It is common practice to locate a spill response kit in a safe area adjacent to the biological process operations. Typical materials in a response kit include protective gear,

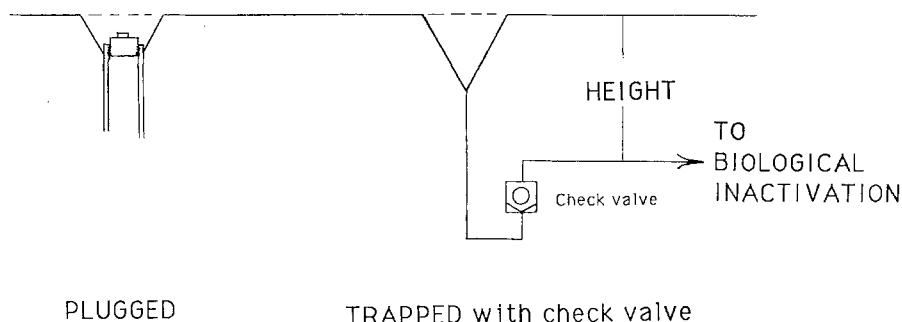

Fig. 11. Floor drain.

such as disposable boots, jump suits, gloves, and breathing protection. The spill kit should also include equipment to contain and recover the spilled materials. This may consist of spill pillows, squeegees, mops and buckets. A decontamination chemical such as bleach or pool chemicals should also be available. All spill response personnel must be trained in the proper use of the personal protective equipment including self-contained breathing apparatus (SCBA) and the proper methods to decontaminate and cleanup spills.

It is good practice to dike around large scale processing equipment. The dike should contain the largest potential process volume and still allow for the addition of an inactivation chemical. Recommendations on the design volume of a diked area range from 1.5–2.0-times the largest process vessel.

Floor drains in any areas of potential biological spills can not be openly connected to the standard process or sanitary sewer service, but should be piped to the biological waste treatment system. This allows spills to be directed to the appropriate inactivation system and effectively serves as secondary containment for the facility. This design can minimize the probability of spills spreading outside the containment area. Floor drains connected to the biological waste treatment system must prevent backflow of waste or vapors from the waste system. This can be accomplished by installing a plug into the connection at each floor drain. When a spill occurs, the appropriate drains plugs are removed and the spill is sent to inactivation treatment. An open floor drain design connected to the biological inactivation system is preferred. This requires a trap of sufficient height be provided to prevent the back flow of aerosols created from the collection of waste from the process areas. The installation of a check valve in the drain line provides assurance that back pressure from the biological treatment system will not compromise the process area (Fig. 11).

## INTEGRATION OF PROCEDURES AND TRAINING WITH DESIGN

Proper design for safe operations only support safe practices. Not having complete and validated procedures in place and an effective training program where those procedures are turned into practices can turn a well designed facility into an accident waiting to happen.

Borrowing the familiar fire triangle concept where air, fuel, and heat are required to support a fire, biosafety can be considered to depend on proper procedures, training, and design (Fig. 12). Take away one of the sides of the triangle and the structure collapses. Similarly, if one of the legs of the biosafety triangle is missing or weak, the biosafety program can collapse. Therefore, a discussion of design can not be complete without emphasizing that procedures and training in safe biological practices is essential.

## ACKNOWLEDGEMENTS

The authors would like to acknowledge the assistance received from the following individuals in the drafting and review of this article; Peter Bigelow, James Kane, Tony Lubiniecki, Richard Rebar and Joseph Waggett.

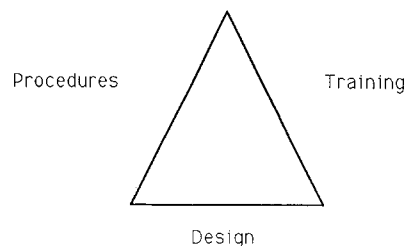

Fig. 12. Biocontainment system triangle.

## REFERENCES

- 1 Centers for Disease Control and National Institutes of Health. May 1988. Biosafety in Microbiological and Biomedical Laboratories. p. 97.
- 2 Geoghegan, R.F. Jr and H.W. Meslar. April 1992. Interphex Seminar WS-1 Biocontainment.
- 3 Giorgio, R.J. and J.J. Wu. March 1986. Design of Large Scale Containment Facilities For Recombinant DNA Fermentations. TIBTech. pp. 60–65.
- 4 Hill, D. and M. Beatrice. October 1989. Biotechnology Facility Requirements, Part 1 – Facility and Systems Design. BioPharm. pp. 20–26.
- 5 Kearns, M.J. July/August 1989. Containment of Biological Hazards: Effect of Guidelines on the Design of Pharmaceutical Facilities and Process Equipment. Pharmaceutical Engineering. Vol. 9, No. 4, pp. 17–21.
- 6 National Institutes of Health. May 7, 1986. Guidelines for Research Involving Recombinant DNA Molecules; Notice. Federal Register Part III, Vol. 51, No. 88, pp. 16958–16985.
- 7 National Institutes of Health. July 18, 1991. Recombinant DNA Research: Actions Under the Guidelines; Notice. Federal Register Part III, Vol. 56, No. 138, pp. 33174–33183.
- 8 Organization for Economic Co-operation and Development. 1986. Recombinant DNA Safety Considerations. pp. 32–36., 53–55.
- 9 Sekhar, C. April 29, 1985. Guidelines For Large-scale r-DNA Fermentations. Chemical Engineering. pp. 57–59.
- 10 Tan, J. Z., R. F. Geoghegan, Jr. and T. C. Tyson. 1989. Liquid Waste Decontamination System in Biomedical and Pharmaceutical Facilities. Bioprocess Engineering Symposium, American Society of Mechanical Engineers.
- 11 Tyler, J.E. March/April 1987. Recombinant DNA Fermentation Pilot Plant Design. Pharmaceutical Engineering. Vol. 7, No. 2, pp. 19–25.
- 12 Van Houten, J., D.O. Fleming, H.W. Meslar, and A.R. Moreira. August 1992. Controlling Biotechnology Risks: A Holistic Approach to Safety and Environmental Protection. Society for Industrial Microbiology Workshop II.
- 13 World Health Organization. 1983. Laboratory Biosafety Manual. WHO Publications Centre, USA. pp. 11–12, 26–27, 29.
- 14 Van Houten, J. and D.O. Fleming. 1993. Comparative analysis of current US and EC biosafety regulations and their impact on the industry. J. Indust. Microbiol. 11: 209–215.